



**MODULARNE
JEDINICE :
TAČKASTO , DUPLO
TAČKASTO ,
LINEARNE**

ALATISTHERM D.O.O

Koče Kapetana 25

35230 Čuprija , Srbija

Tel/fax : + 381 (0) 35 8471- 196

Mob 1 : + 381 (0) 65 2771- 802

Mob 2 : + 381 (0) 65 8410- 651

office@alatismtherm.in.rs

office@alatismtherm.co.rs

www.alatismtherm.co.rs

OPIS MODULARNOG SISTEMA

Multi jedinice - linije za tačkasto zavarivanje. Ove linije se proizvode u različitim kombinacijama : Tačkasto zavarivanje - punktovanje , Duplo tačkasto zavarivanje – Duplo punktovanje , Punktovanje sa linearnim vođenjem.

ŠEMA JEDNOG MULTI SISTEMA

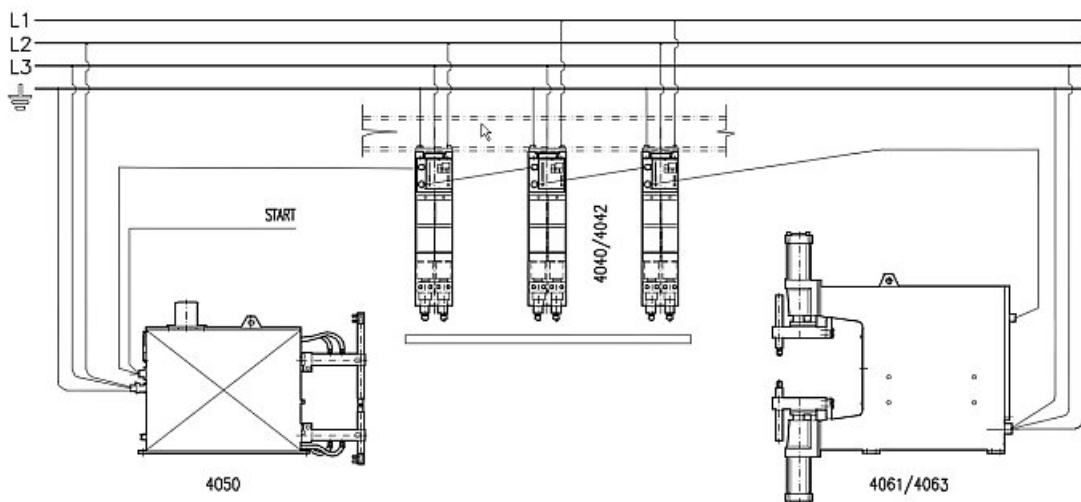

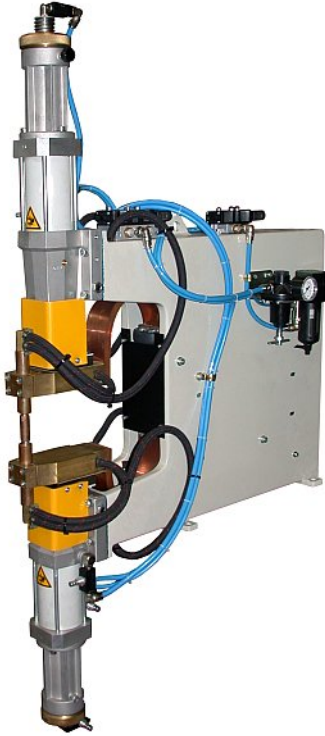

SPECIJALNE KONSTRUKCIJE

- Različite dužine ruku
- Linearno vođenje obe elektrode
- Linarne za projekciono punktovanje
- Sa pozicionim senzorima za hod
- Bez kontrolne jedinice ako cela linija ima centralnu kontrolnu jedinicu

ALATISTHERM D.O.O

Koče Kapetana 25

35230 Čuprija , Srbija

Tel/fax : + 381 (0) 35 8471- 196

Mob 1 : + 381 (0) 65 2771- 802

Mob 2 : + 381 (0) 65 8410- 651

office@alatismtherm.in.rs

office@alatismtherm.co.rs

www.alatismtherm.co.rs

JEDINICE ZA DUPLO PUNKTOVANJE 4040 , 4041 , 4042 , 4043...32 KVA



Ove konfiguracije obavljaju punktovanje elektrodama koje su samo sa jedne strane radnog predmeta. Zbog toga ne mogu biti upotrebljavane u klasičnim konfiguracijama za punktovanje.

Dostupne su u varijantama :

- sa ili bez kontrolne jedinice TE93
- sa 50 mm ili 80 mm radnog hoda.

Velikim izborom nosača elektroda I elektroda uređaj se može podesiti za rad prema potrebama.

Vodom hlađeni I epoksi smolom izolovan transformator.

Vodom hlađeni nosači elektrode I elektrode.

Bezuljne pneumatske komponente.

PRIMERI DUPLOG PUNKTOVANJA

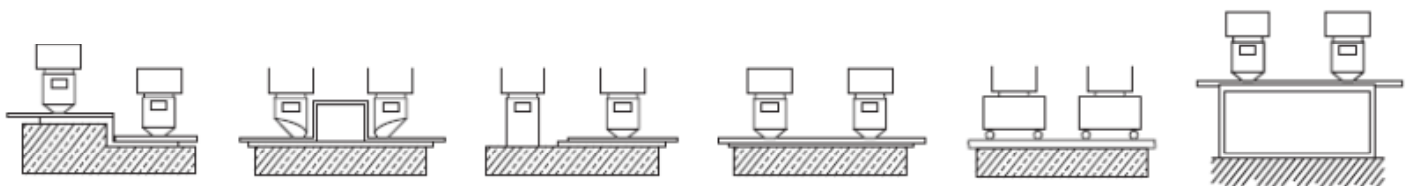

4044 – Dostupan je I zaseban trafo koji se može koristiti sa jedinicama 4041 , 4043 kako bi se napravio sistem push – pull (guraj – vuci).

Kada se pravi ovakva konfiguracija neophodno je imati zasebne kontrolne jedinice I zasebna napajanja. Dokumentaciju vam možemo poslati na vaš zahtev.

Sa ovom push-pull konfiguracijom se povećava debljina koja može da se zavaruje – punktuje I povećava se takođe kvalitet zavarenog spoja.

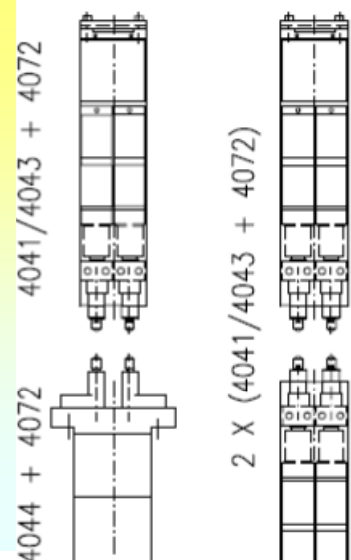

TEHNIČKE KARAKTERISTIKE JEDINICA ZA DUPLO PUNKTOVANJE

ITEM		4040	4041	4042	4043
Elektronski tajmer TE93		•	-	•	-
Nominalna snaga na 50%	kVA	32	32	32	32
Maksimalna snaga	kVA	96	96	96	96
Struja kratkog spoja	kA	20	20	20	20
Maksimalna struja na limu	kA	16	16	16	16
Termička struja 100%	A	3800	3800	3800	3800
Sekundarni napon praz. hoda	V	5.9	5.9	5.9	5.9
Priključni napon 50Hz *	V	400	400	400	400
Presek kabla L=10 m	mm ²	10	10	10	10
Presek kabla L=30 m	mm ²	25	25	25	25
Spori osigurači	A	63	63	63	63
Minimum prostor	mm	38	38	38	38
Maximum prostor	mm	150	150	150	150
Max. sila elektrode (6 bar)	daN	2x260	2x260	2x260	2x260
Max. hod elektrode	mm	50	50	80	80
Komprimovani vazduh	bar	1-6	1-6	1-6	1-6
Vazduh za 1000 puntova (6 bar)					
Hod 20 mm	Nm ³	2	2	2	2
max. hod	Nm ³	5.2	5.2	8.2	8.2
Crevo za vazduh	mm	8	8	8	8
Hlađenje vodom	l/min	4	4	4	4
Nivo buke	dB(A)	< 70	< 70	< 70	< 70
Merni uslovi					
Radni hod	mm	20	20	20	20
Vreme zavarivanja	cycles	8	8	8	8
Struja zavarivanja	kA	15	15	15	15
Frekvencija rada u punkt/min		15	15	15	15
Neto težina (približno)	kg	69	66	70	67

ALATISTHERM D.O.O, Koče Kapetana 25, 35230 Ćuprija, Srbija
 Tel/fax : + 381 (0) 35 8471- 196, Mob 1 : + 381 (0) 65 2771- 802
 Mob 2 : + 381 (0) 65 8410- 651, office@alatistherm.in.rs
office@alatistherm.co.rs, www.alatistherm.co.rs









6

CENE V.P JEDINICA ZA DUPLO PUNKTOVANJE – cene nisu konačne

4040	Twin spot welding group, 32 kVA, with control unit TE93 and built-in SCR. Electrodes stroke 50 mm. Equipped with supply cable L=4m and control cable item 4076. Electrode-holders are not included.	€ 5.200,00
4042	Twin spot welding group, 32 kVA, with control unit TE93 and built-in SCR. Electrodes stroke 80 mm. Equipped with supply cable L=4m and control cable item 4076. Electrode-holders are not included.	€ 5.740,00
4041	Twin spot welding group, 32 kVA, without control unit. Electrodes stroke 50 mm. Equipped with supply cable L=4m. Electrode-holders are not included.	€ 4.425,00
4043	Twin spot welding group, 32 kVA, without control unit. Electrodes stroke 80 mm. Equipped with supply cable L=4m. Electrode-holders are not included.	€ 5.020,00
4044	Lower welding transformer 25 kVA to be used for carrying out a push-pull welding system. It can be combined with items 4041 and 4043 only.	€ 1.315,00

NOSAČI ELEKTRODA I DODACI ZA DUPLO PUNKTOVANJE – naručuju se zasebno - dodatno

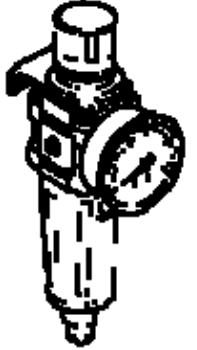
	Item 4072 - Nosač elektroda par, duži tip (H= 75 mm) sa elektrodama item 4720, ukupna dužina oko 100 mm. Elektrodni konus prečnika 18 mm.
	Item 4073 - Nosač elektroda par, kraći tip (H= 50 mm) sa elektrodama item 4719, ukupna dužina oko 100 mm. Elektrodni konus prečnika 18 mm

	Item 4021 - Nosač elektroda par, duži tip (H= 75 mm) sa elektrodama item 8701, ukupna dužina oko 115 mm. Elektrodni konus prečnika 19.05 mm.(3/4") BS807
	Item 4074 – Par nosača elektroda sa nožastim tipom elektroda
	Item 4076 - Interkonekcioni kabal L=1,2m (Items 4040 i 4041 imaju ovaj kabal)
	Item 4077 - Filter-regulator grupa sa satom, za najviše 2 jedinice
	Item 4078 – Muška utičnica, 6 kontakata , za kontrolu signala jedinica za zavarivanje

CENOVNIK V.P DODATAKA ZA DUPLO PUNKTOVANJE

4076	Connection cable among welding units with 6 poles + ground, length 1.2 m.	€	40,50
4077	Filter regulator group with gauge, to connect max. 2 units	€	221,00
4078	Male connector 6 poles + ground, to connect the control signals of the welding units	€	24,00

ALATISTHERM D.O.O

Koče Kapetana 25

35230 Čuprija , Srbija

Tel/fax : + 381 (0) 35 8471- 196

Mob 1 : + 381 (0) 65 2771- 802

Mob 2 : + 381 (0) 65 8410- 651

office@alatistherm.in.rs

office@alatistherm.co.rs

www.alatistherm.co.rs

CENOVNIK V.P ELEKTRODA Ø 18 ZA DUPLO PUNKTOVANJE

4072	Pair of electrode-holders, long type (H= 75 mm) with electrodes item 4720, total height approx.100 mm	€ 189,00
4073	Pair of electrode-holders, short type (H= 50 mm) with electrodes item 4719, total height approx. 100 mm	€ 172,00
4074	Pair of knife-type electrode-holders with electrodes item 4075	€ 324,00
4075	Pair of knife-type electrodes mm.80x50x15 (for electrode-holder 4074)	€ 55,50
4717	Pair of flat "long" electrodes (for electrode-holder 4073)	€ 41,00
4718	Pair of offset "long" electrodes (for electrode-holder 4073)	€ 33,50
4719	Pair of straight "long" electrodes (for electrode-holder 4073)	€ 43,50
4720	Pair of straight electrodes (for electrode-holder 4072)	€ 21,00
4721	Pair of offset electrodes (for electrode-holder 4072)	€ 33,50
4722	Pair of angled electrodes (for electrode-holder 4072)	€ 29,00
4723	Pair of bent electrodes (for electrode-holder 4072)	€ 92,00
4724	Pair of flat electrodes (for electrode-holder 4072)	€ 40,00
4725	Swivel electrode (for electrode-holder 4072)	€ 46,00

CENOVNIK V.P ELEKTRODA Ø 19 ZA DUPLO PUNKTOVANJE

8701	Straight electrodes (pair)	€ 34,00
8702	Flat electrodes (pair)	€ 60,00
8703	Offset electrodes (pair)	€ 48,00
8705	Angled electrodes with offset tip (pair)	€ 48,00
8706	Bent electrodes (pair)	€ 113,00
4021	Pair of electrode-holders (for 8701)	€ 168,00

ALATISTHERM D.O.O
Koče Kapetana 25
35230 Ćuprija , Srbija
Tel/fax : + 381 (0) 35 8471- 196
Mob 1 : + 381 (0) 65 2771- 802
Mob 2 : + 381 (0) 65 8410- 651
office@alatistherm.in.rs
office@alatistherm.co.rs
www.alatistherm.co.rs

LINEARNE JEDINICE ZA PUNKTOVANJE 4060 , 4061 , 4062 , 4063 SA JEDNIM ili DVA CILINDRA - na gornjem ili oba elektrodna nosača .. 32 ili 63 KVA

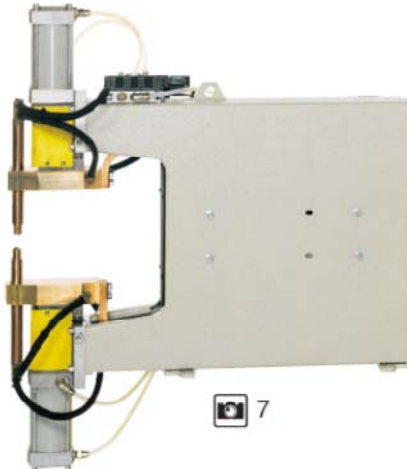

Ove konfiguracije su sa kontrolnom jedinicom TE93.

Dostupne su u varijantama :

- sa jednim cilindrom – gornjim (donji nosač je nepokretan)
- sa dva cilindra – oba nosača su pokretna

Cr-Cu nosači elektroda sa dugim eksploatacionim vekom.

Vodom hlađeni i epoksi smolom izolovan transformator .

Vodom hlađeni nosači elektrode i elektrode.



Bezuljne pneumatske komponente

Cilindri sa Cr površinama klipova.

TEHNIČKE KARAKTERISTIKE

ITEM	ART.		4060	4061	4062	4063
Picture	Photo	N°	3	7	3	7
Nominal power at 50%	Puissance conventionnelle à 50%	kVA	36	36	63	63
Maximum welding power	Puissance maximum	kVA	90	90	192	192
Short circuit current	Courant de court circuit	kA	18	18	24	24
Maximum welding current on steel	Courant maximum de soudage sur acier	kA	14.4	14.4	19.2	19.2
Thermal current 100%	Courant thermique 100%	kA	4	4	4.4	4.4
No load secondary voltage	Tension secondaire à vide	V	6.3	6.3	10	10
Supply voltage 50Hz	Tension d'alimentation 50Hz	V	400	400	400	400
Delayed fuses	Fusibles à grande inertie	A	63	63	120	120
Depth L	Profondeur L	mm	290	290	290	290
Electrodes Ø	Electrodes Ø	mm	14,8	14,8	14,8	14,8
Max. electrode force (6 bar)	Force maximum aux électrodes (6 bar)	daN	300	300	470	470
Maximum stroke	Course maximum	mm	80	80	80	80
Compressed air supply	Alimentation air comprimé	bar	1÷6	1÷6	1÷6	1÷6
Air for 1000 spots (6 bar)	Air pour 1000 points (6 bar)					
total stroke	course totale	Nm³	5.4	10.8	8.7	17.4
20 mm stroke	course 20mm	Nm³	1.7	3.4	2.6	5.2
Water cooling	Refroidissement par eau	l/min	4	4	4	4
Net weight (approximately)	Poids net (à peu près)	kg	88	90	111	113

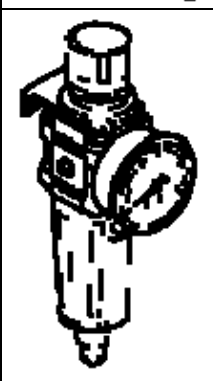
DODACI ZA 4060 , 4061 , 4062 , 4063

	Item 4076 - Interkonekcionni kabal L=1,2m
	Item 4077 - Filter-regulator grupa sa satom, za najviše 2 jedinice
	Item 4078 – Muška utičnica, 6 kontakata , za kontrolu signala jedinica za zavarivanje

CENE V.P JEDINICA 4060 , 4061 , 4062 , 4063 – cene nisu konačne

4060	Linear action welding unit 36kVA, with control unit TE93 and built-in SCR. Execution with 300 daN cylinder. Equipped with supply cable L=4m and control cable item 4076	€ 8.965,00
4061	Linear action welding unit 36kVA, with control unit TE93 and built-in SCR. Execution with two opposite cylinders 300 daN. Equipped with supply cable L=4m and control cable item 4076	€ 10.160,00
4062	Linear action welding unit 63kVA, with control unit TE93 and built-in SCR. Execution with 470 daN cylinder. Equipped with supply cable L=4m and control cable item 4076.	€ 10.160,00
4063	Linear action welding unit 63kVA, with control unit TE93 and built-in. Execution with two opposite cylinders 470 daN. Equipped with supply cable L=4m and control cable item 4076.	€ 11.350,00

CENOVNIK V.P DODATAKA ZA 4060 , 4061 , 4062 , 4063

4076	Connection cable among welding units with 6 poles + ground, length 1.2 m.	€ 40,50
4077	Filter regulator group with gauge, to connect max. 2 units	€ 221,00
4078	Male connector 6 poles + ground, to connect the control signals of the welding units	€ 24,00

CENOVNIK V.P ELEKTRODA ZA 4050 , 4060 , 4061 , 4062 , 4063

4564	Brass reduced-size arm with electrode holder, $\varnothing=65$, D=40, L ₁ =300, L=380mm (for item 4050 only)	€	252,00
4565	Brass reduced-size arm with front electrode, $\varnothing=50$, D=40, L ₁ =300, L=380 mm. Supplied with electrode-holder item 4726 and electrode item 4727 (for item 4050 only)	€	296,00
4726	Electrode-holder for reduced-sized arm item 4565 with electrode item 4727	€	112,00
4727	Offset electrode for item 4726 (for reduced size arm item 4565)	€	7,00
4729	Straight electrode for item 4726 (for reduced size arm item 4565)	€	6,50
3620	Straight electrodes - taper 14,8 (a pair)	€	18,00
3621	Offset electrodes - taper 14,8 (a pair)	€	19,00
3622	Angled electrodes - taper 14,8 (a pair)	€	25,50
3623	Bent electrodes - taper 14,8 (a pair)	€	43,00
3624	Flat electrodes - taper 14,8 (a pair)	€	19,00
3625	Swivel electrode diam. 30 - taper 14,8	€	48,50

ALATISTHERM D.O.O

Koče Kapetana 25

35230 Čuprija , Srbija

Tel/fax : + 381 (0) 35 8471- 196

Mob 1 : + 381 (0) 65 2771- 802

Mob 2 : + 381 (0) 65 8410- 651

office@alatistherm.in.rs

office@alatistherm.co.rs

www.alatistherm.co.rs

MODULAR SISTEM - KLASIČNE JEDINICE ZA PUNKTOVANJE 4050 20 KVA











- Klasična jedinica za tačkasto zavarivanje – punktovanje sa procesorom TE93.
- Podesiva dužina ruku do 320 mm.
- Cr-Cu nosači elektroda sa dugim radnim vekom.
- Podesiv zamah – hod elektroda.
- Vodom hlađeni trafo sa epoksi smolom kao zaštitom.
- Vodom hlađene ruke , elektrode , nosači elektrode.
- Sinhronizovani SCR prekidač.
- Bezuljni pneumatski cilindar.

TEHNIČKE KARAKTERISTIKE za 4050

ITEM		4050
Nominalna snaga na 50%	kVA	20
MAksimalna snaga	kVA	51
Struja kratkog spoja	kA	15.5
MAksimalna struja za čelik - lim	kA	12.4
Termička struja 100%	A	3500
Sekundarni napon praznog hoda	V	4
Napojni napon 50Hz *	V	400
Presek kabla L=30 m	mm ²	10
Osigurači	A	40
Min. dubina ruku	mm	180
Max. sila elektroda (6 bar)	daN	320
Hod elektroda	mm	5-28
Max. dubina ruku	mm	500

Max. sila elektroda (6 bar)	daN	130
Hod elektroda	mm	5-74
Razmak između ruku	mm	220
Prečnik ruku	mm	40
Prečnik nosača elektroda	mm	22
Standardne elektrode prečnika	mm	14.8
Komprimovani vazduh	bar	1-6
Vazduh za 1000 punktova (6 bar)		
min. dubina ruku - hod 20 mm	Nm ³	2.5
max. hod	Nm ³	3
Crevo za vazduh	mm	8
Protok rashladnog sredstva	l/min	4
Nivo buke	dB(A)	< 70
Merni uslovi		
Radni hod	mm	20
Vreme zavarivanja	cycles	26
Struja zavarivanja	kA	9
frekvencija u punktovi/min		10
Neto težina (približno)	kg	88

VRHOVI ELEKTRODA

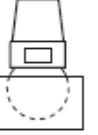
Ø 14.8 mm	-	-	-	3620 l	3621 l	3622 l	3623 l	3624 l	3625 n
Ø 18 mm	4717 l	4718 l	4719 l	4720 l	4721 l	4722 l	4723 l	4724 l	4725 n
Ø 19.05 mm	-	-	-	8701 l	8703 l	8705 l	8706 l	8702 l	-
									

CENA V.P UREĐAJA 4050

4050	Rocker arm welding unit 20kVA, with control unit TE93 and built-in SCR. Adjustable arms length from 180 to 500 mm. Equipped with supply cable L=4m and control cable item 4076.	€ 3.590,00
-------------	---	-------------------

ALATISTHERM D.O.O

Koče Kapetana 25

35230 Čuprija, Srbija

Tel/fax : + 381 (0) 35 8471- 196

Mob 1 : + 381 (0) 65 2771- 802

Mob 2 : + 381 (0) 65 8410- 651

office@alatistherm.in.rs

office@alatistherm.co.rs

CENA V.P ELEKTRODA za 4050

4564	Brass reduced-size arm with electrode holder, $\varnothing=65$, D=40, L ₁ =300, L=380mm (for item 4050 only)	€ 252,00
4565	Brass reduced-size arm with front electrode, $\varnothing=50$, D=40, L ₁ =300, L=380 mm. Supplied with electrode-holder item 4726 and electrode item 4727 (for item 4050 only)	€ 296,00
4726	Electrode-holder for reduced-sized arm item 4565 with electrode item 4727	€ 112,00
4727	Offset electrode for item 4726 (for reduced size arm item 4565)	€ 7,00
4729	Straight electrode for item 4726 (for reduced size arm item 4565)	€ 6,50
3620	Straight electrodes - taper 14,8 (a pair)	€ 18,00
3621	Offset electrodes - taper 14,8 (a pair)	€ 19,00
3622	Angled electrodes - taper 14,8 (a pair)	€ 25,50
3623	Bent electrodes - taper 14,8 (a pair)	€ 43,00
3624	Flat electrodes - taper 14,8 (a pair)	€ 19,00
3625	Swivel electrode diam. 30 - taper 14,8	€ 48,50
4717	Pair of flat "long" electrodes (for electrode-holder 4073)	€ 41,00
4718	Pair of offset "long" electrodes (for electrode-holder 4073)	€ 33,50
4719	Pair of straight "long" electrodes (for electrode-holder 4073)	€ 43,50
4720	Pair of straight electrodes (for electrode-holder 4072)	€ 21,00
4721	Pair of offset electrodes (for electrode-holder 4072)	€ 33,50
4722	Pair of angled electrodes (for electrode-holder 4072)	€ 29,00
4723	Pair of bent electrodes (for electrode-holder 4072)	€ 92,00
4724	Pair of flat electrodes (for electrode-holder 4072)	€ 40,00
4725	Swivel electrode (for electrode-holder 4072)	€ 46,00
8701	Straight electrodes (pair)	€ 34,00
8702	Flat electrodes (pair)	€ 60,00
8703	Offset electrodes (pair)	€ 48,00
8705	Angled electrodes with offset tip (pair)	€ 48,00
8706	Bent electrodes (pair)	€ 113,00
4021	Pair of electrode-holders (for 8701)	€ 168,00

ALATISTHERM D.O.O

Koče Kapetana 25

35230 Čuprija, Srbija

Tel/fax : + 381 (0) 35 8471- 196

Mob 1 : + 381 (0) 65 2771- 802

Mob 2 : + 381 (0) 65 8410- 651

office@alatistherm.in.rs

office@alatistherm.co.rs

www.alatistherm.co.rs

UGRADNE MERE UREĐAJA 4050

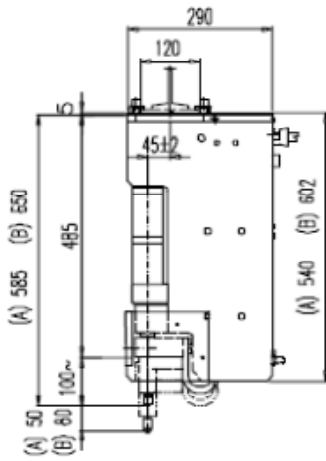

Art. 4040 (A)
Art. 4042 (B)

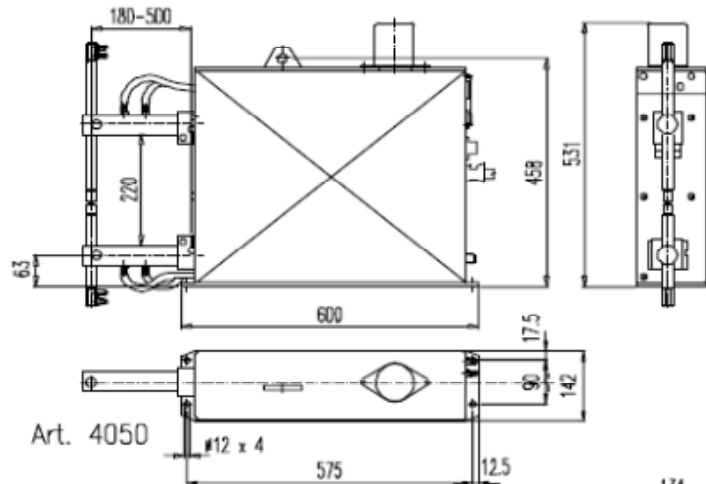
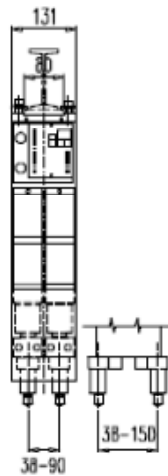

Art. 4050

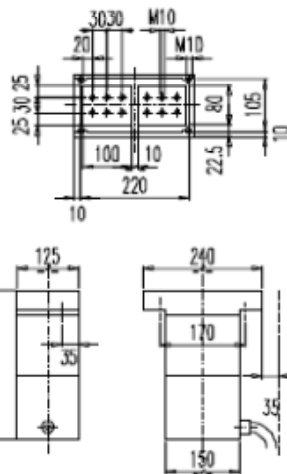

Art. 4044

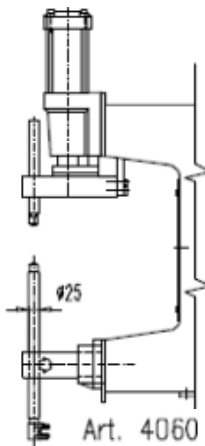

Art. 4060
Art. 4062

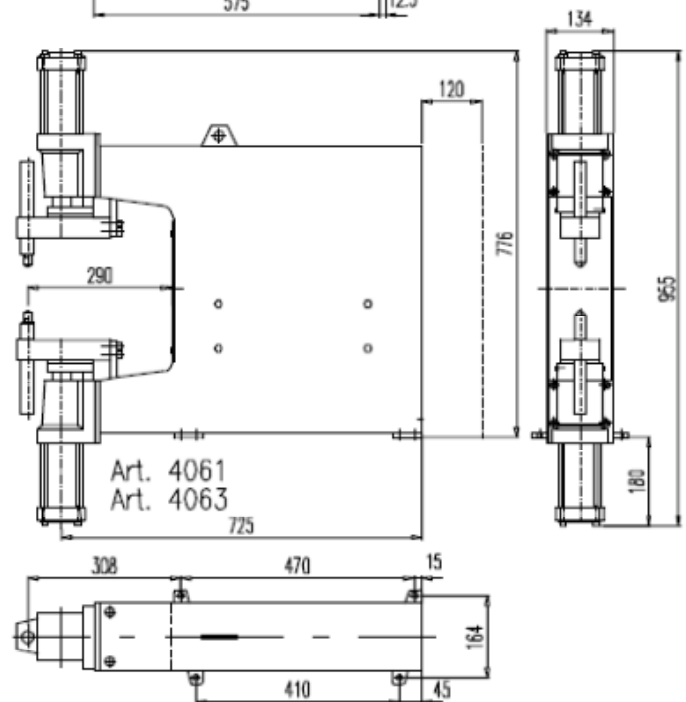

Art. 4061
Art. 4063

ALATISTHERM D.O.O

Koče Kapetana 25

35230 Čuprija, Srbija

Tel/fax : + 381 (0) 35 8471- 196

Mob 1 : + 381 (0) 65 2771- 802

Mob 2 : + 381 (0) 65 8410- 651

office@alatistherm.in.rs

office@alatistherm.co.rs

www.alatistherm.co.rs

MODULARNI SISTEMI – 72255 , 72256 – “ C “ tip – “ X “ tip



72255 , 72256

Ove jedinice predstavljaju samo komponente koje koriste proizvođači koji proizvode sisteme za tačkasto zavarivanje.

Ne mogu ih koristiti krajnji korisnici je rove jedinice nisu kompletirane za takvu upotrebu

ALATISTHERM D.O.O

Koče Kapetana 25

35230 Ćuprija , Srbija

Tel/fax : + 381 (0) 35 8471- 196

Mob 1 : + 381 (0) 65 2771- 802

Mob 2 : + 381 (0) 65 8410- 651

office@alathetherm.in.rs

office@alathetherm.co.rs

www.alathetherm.co.rs